

# Recycling tank 50CC

Art. no. —

Painted steel recycling tank with twin scraper conveyor.



Illustrations may differ from the actual scope of delivery

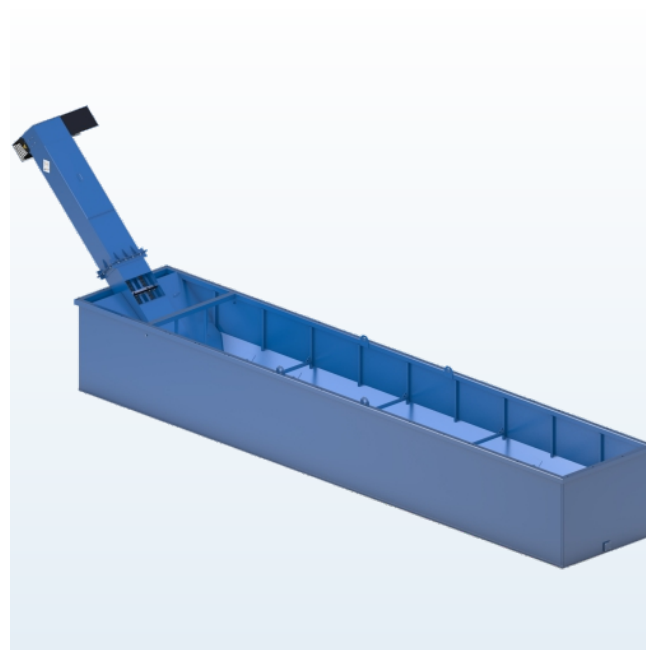

## Function

The washed-off solids settle out in the recycling tank. The integrated twin scraper conveyor conveys settled sludge from the recycling tank. It is recommended to use the MobyDos Compact flocculant dosing system (optional).

## Technical description

Recycling tank consisting of a solid steel structure with profile frame ( $\frac{3}{4}$  in) and steel plates. Surface treatment by chemical cleaning, primer 2.4  $\mu\text{m}$  and top coat 2.4  $\mu\text{m}$  Traffic blue (RAL 5017). Integrated twin scraper conveyor consisting of gear motor, drive and deflection shafts, conveyor chains with dirt scrapers and guide rails. Two drain covers for easy emptying of the tank. The tank construction allows it to sustain all the forces generated by a passing loaded truck even when empty.

## Specifications

• Dimensions (H×W×L)	160×87×538 in
• Dimensions recycling tank (H×W×L)	65×87×457 in
• Ejection height (above recycling tank) *	75 in
• Electrical connection values	0.74 HP/2.5 A
• Weight (ready to ship) *	11,050 lbs
• Material	Steel
• Color	Traffic blue (RAL 5017)

\* in accordance with "Technical description"

## General scope of supply

- Recycling tank
- Twin scraper conveyor
- Scraper conveyor access protection
- Additional components dependent on recycling tank design, for example: baffle, level control, rim elevations, tank connections